

Dominik WYSZYNSKI<sup>1</sup>  
Sebastian SKOCZYPIEC<sup>1</sup>  
Karolina FURYK<sup>1</sup>

## **MATHEMATICAL MODELLING OF THE LASER MACHINING PROCESS OF SAPPHIRE CRYSTAL Al<sub>2</sub>O<sub>3</sub>**

The paper presents theoretical aspects concerning use of pulse laser source for precise machining of Al<sub>2</sub>O<sub>3</sub> crystals for medical applications. The scheme of laser beam manipulation and the test stand has been presented. Application of the mathematical model enabled determination of values of basic sapphire machining parameters. Presented results give rough information about dynamics of the process and can be used for the test stand designing as well as determination of machining precision.

### **1. INTRODUCTION**

Rapid development in various fields of technology including biomedical engineering, determines dynamic progress in manufacturing technology. Appearing on the market modern materials such as cemented carbides, cermets, dense and porous bioceramics and artificial diamond greatly influence development of the existing and creation of new advanced methods for material's treatment. Sapphire and ruby in medicine is the newest and quickly developing field of mass application [1]. It can be implanted in the body tissue since they do not react with organic acids, alkalis and their inertness compare favorably with constructional metals and alloys. At the same time ruby and sapphire are very hard and shaping crystal into the necessary form is possible weather with a harder diamond or other unconventional method. Due to many profits connected with possibility of shaping of super hard materials it is of great importance to develop unconventional methods such for their treatment as electrochemical machining, ultrasonic machining or laser machining. The last one is more and more often applied because of unusual and unique properties of the laser beam [2]. These properties enable performing precise operations on difficult to cut materials in low cost and time consuming way.

---

<sup>1</sup> Cracow University of Technology, Faculty of Mechanical Engineering, Poland

## 2. LASER BEAM MACHINING

Understanding the capabilities and limitations of laser machining requires the knowledge of physical processes occurring during the laser beam interactions with materials [3]. When the laser beam incidents the surface of the material, various phenomena occur like reflection, refraction, absorption, scattering, and transmission.

Laser processing is one of the alternatives to traditional methods of material removing such as milling, cutting or turning in production of precision components and micro parts. It is used for a wide range of materials as metals, ceramics or composite materials.

One of the most desirable and important phenomena in the laser processing of materials is the absorption of the radiation.

Absorption of radiation in the materials results in various effects like heating, melting, vaporization [4]. The extent of these effects primarily depends on the characteristic of laser beam and the thermo-physical properties of the material. The laser parameters include intensity, wavelength, angle of incidence, polarization, illumination time, Whereas the materials parameters are absorptivity, thermal conductivity, specific heat, density, latent heat.

## 3. MATHEMATICAL MODEL

Present mathematical model takes into account the two parts:

- the first part of the mathematical model takes into account the effect of laser beam polarization on absorption,
- the second part we take into account the temperature in the workpiece.

The polarization control methods are used in laser cutting in order to improve accuracy and edge quality. There can be distinguished three different types of polarization: linear, circular and elliptical. Idea of electromagnetic wave and the scheme of polarization type and how polarization vector combination to machining direction affects quality of the cutting edge was presented in [5].

The linearly polarized wave is characterized by oscillations of electrical field vector that take place in one plane, perpendicular to the direction of wave propagation. In this configuration the electric field vector can be oriented horizontally or vertically to the direction of machining. The circular polarization of light wave is when the electric field vector determined along the direction of the wave has always the same value, but its direction is changing. Circularly polarized wave can be obtained by a superposition of two waves with equal amplitudes and frequencies, propagating in the same direction, linearly polarized in perpendicular directions, and shifted in phase upon a suitable angle. Elliptically polarized wave can be obtained by a superposition of two waves with identical frequencies, propagating in the same direction, linearly polarized in mutually perpendicular directions, shifted in phase upon a suitable angle, but with different amplitudes. It can also be obtained as the composition of waves with linear and circular polarization.

The electric field vector ( $E$ ) extends into the side walls of the cut as opposed to running along the direction of cutting. Beam polarization determines direction of electric vector during the cutting process.

In the mathematical model there are considered two directions of laser beam polarization in relation to the direction of cutting: parallel and perpendicular. Beam polarization determines direction of electric vector during the cutting process.

The cutting made with the electric field vector parallel to the direction of the cut. The cut on the right side of the figure was made with the electric field vector ( $E$ ) perpendicular to the direction of the cut extends into the side walls. One can see that the edge of the cut quality is much better for the parallel polarization but the cutting speed is lower than when cutting perpendicular polarization. Intermediate solution is the use of circular polarization. The solution for perpendicular polarization is much more beneficial because large temperature gradient on the edges. This results are determined by interaction between electric field and electrons in machined material.

The data for mathematical calculations assume the parameters of the laser parameters shown in the figure below:

Table 1. The parameters of the laser

<i>Laser Type</i>	<i>DPSS Nd:YAG</i>
<i>Model</i>	<i>PA-016-QTG</i>
<i>Wavelength</i>	<i>532 nm</i>
<i>Pulse Repetition Rate</i>	<i>4 to 15 kHz</i>
<i>Pulse energy</i>	<i>2,5mJ@9kHz</i>
<i>Output power</i>	<i>23 W@ 9 kHz</i>
<i>Beam Diameter @ Output Window</i>	<i>0,9 mm @ 9 kHz</i>
<i>Polarization</i>	<i>Linear</i>

Mathematical modelling which takes into account polarization of the laser beam is based on Fresnel formulae. Based on these formulae, one can calculate the reflectivity for the parallel and perpendicular polarization. But it is worth to note that this equation does not include the laser beam wavelength. The purpose of the modelling is to know how it would change the reflection coefficient  $r$  depending on the material parameters as:

$$\frac{E_r}{E_i} = r_s = \frac{n_1 \cos \alpha - \frac{\mu_1}{\mu_2} \sqrt{n_2^2 - n_1^2 \sin^2 \alpha}}{n_1 \cos \alpha + \frac{\mu_1}{\mu_2} \sqrt{n_2^2 - n_1^2 \sin^2 \alpha}} \quad (1)$$

$$\frac{E_r}{E_i} = r_p = \frac{\frac{\mu_1}{\mu_2} n_2^2 \cos \alpha - n_1 \sqrt{n_2^2 - n_1^2 \sin^2 \alpha}}{\frac{\mu_1}{\mu_2} n_2^2 \cos \alpha + n_1 \sqrt{n_2^2 - n_1^2 \sin^2 \alpha}} \quad (2)$$

$\mu_1, \mu_2$  – magnetic permeability of media 1 and 2, respectively,  $n_1$  and  $n_2$  are the indices of refraction of the two media,  $E_i$  – electric field of the incident beam;  $E_r$  – electric field of the reflected beam and  $\alpha$  stands for the angle of beam incidence.

When the phase differences between the fields are not of interest it is advisable not to use the amplitudes but the squares of the absolute values of the amplitudes.  $R_s$  and  $R_p$  thus give the ratio of the intensities of the incident waves respectively:

$$R_s = r_s^2, R_p = r_p^2 \quad (3)$$

Figure above shows the relation between reflectance and angle of incidence. The graph shows that at a certain angle called Brewster's angle for the parallel polarization, the reflection of the beam is equal to zero. Theoretically, the process should be carried in this angle of laser beam incidence. In practice, the laser beam incident at that angle has instead of a circular cross section the elliptical one. This combination causes an anisotropic decrease in power density, which excludes machining at this angle.

Focused laser beam waist can be calculated from presented below formula:

$$d_f = \frac{4\lambda f}{\pi d} \quad (4)$$

where:  $\lambda$  is laser wavelength,  $f$  is focusing lens focal length,  $d$  – beam diameter.

The next step in the calculations was to incorporate changes in temperature on the surface of the workpiece.

Boundary conditions adopted during of modelling:

- no heat exchange of by radiation, convection and electrolyte flow,
- the workpiece has limited size and there is no clamping, where the heat could be transferred to the working table.

Data to calculate the temperature change of the material:  $T_0$  – room temperature,  $\rho$  – mass density - 3990kg/m<sup>3</sup>,  $c$  - specific heat - 761J/(kg·K),  $v$  – machining velocity — 0,01 to 1 m/s,  $K$  – heat conductivity - 24W/(m·K),  $P$  – resulting laser power — 20W.

At distances that are large compared to the laser spot size on the surface the details of the laser intensity distribution is inessential. In that case the source can be assumed to be a point source. In presented case, it cannot be assumed like that because the laser is used for micromachining. Therefore, it was assumed that the temperature distribution will be conducted in accordance with Gaussian intensity distribution.

Analysis was performed for workpiece with a plane surface that extends into half-space. We assume that within the beam radius 87% of the beam power is contained. The temperature distribution is given by the formula below [6]:

$$T(x, y, z, t) - T_{-\infty} = \frac{2P_L}{\rho c} \times \frac{1}{4\pi\kappa(t-t')} \cdot \frac{1}{4\pi\kappa(t-t') + \frac{w_0^2}{2}} \times \exp\left[-\frac{(x-v(t-t'))^2 + y^2}{4\pi\kappa(t-t') + \frac{w_0^2}{2}}\right] \times \exp\left[-\frac{z^2}{4\kappa(t-t')}\right] dt' \quad (5)$$

Variables in this equation are:  $P_L$  - corrected laser power,  $w_0$  - beam waist,  $\rho$  - mass density,  $c$  - specific heat capacity,  $\kappa$  - temperature conductivity.

#### 4. RESULTS OF THE MODELLING

The modelling revealed interesting results. In the first stage it was calculated the laser beam waist size in order to simulate interaction between the laser light and material. The focusing lens in the test stand should be distortion free and have long focal length in order to gain high precision and versatility of machining, Therefore focusing triplet was assumed and following parameters used:  $\lambda = 532 \cdot 10^{-9} \text{m}$ ,  $f = 77 \cdot 10^{-3} \text{m}$ ,  $d = 6 \cdot 10^{-3} \text{m}$ , Resulting focused beam waist is:  $d_{f-532} = 8,7 \mu\text{m}$ .

Then using formula (5) and MatLab presented below figures were prepared – Figs. 1 and 2. For laser power  $P=20\text{W}$ , and cutting speeds  $v = 10\text{mm/s}$ ,  $v = 100\text{mm/s}$  and  $v = 1000\text{mm/s}$  dependencies were calculated.

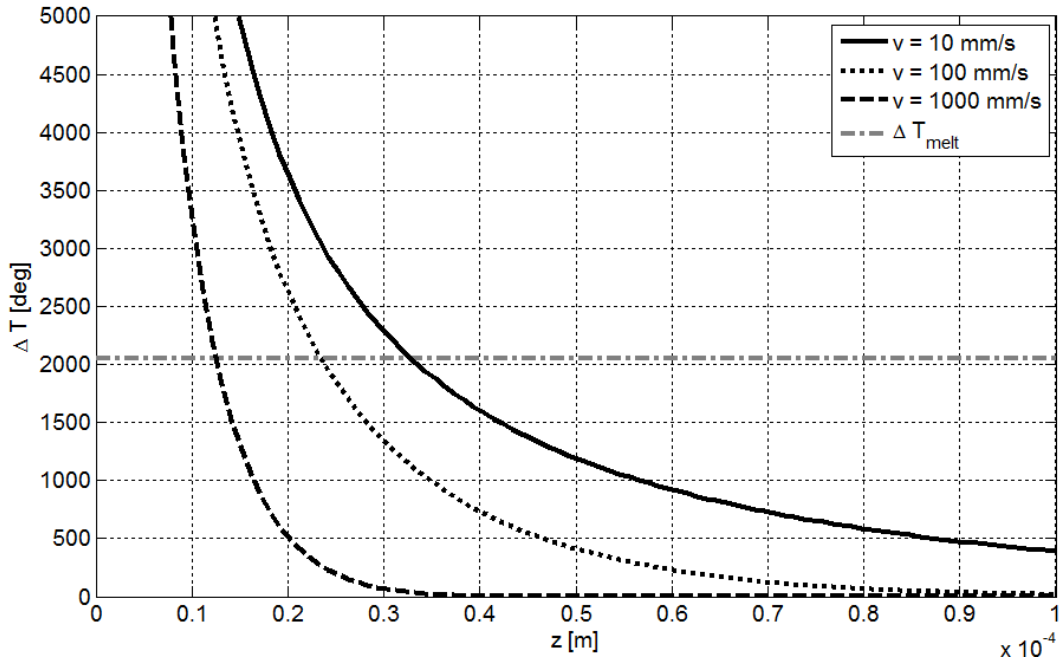

Fig. 1. Temperature rise inside the material depending on cutting speed. Dashed horizontal line represents melting point.

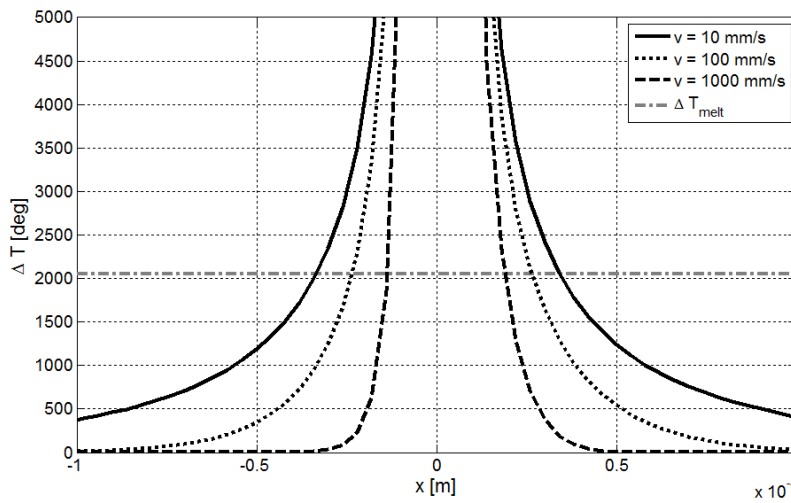

Fig. 2. Temperature rise on the surface of the material depending on cutting speed. Dashed horizontal line represents melting point.

It can be noticed that cutting speed strongly affects temperature rise inside and on the surface of the material. It may be obvious that for precision machining higher cutting speed should be applied. But 1000mm/s is very high value and it is extremely difficult to build up the test stand fulfilling such a requirements because of kinematics and stiffness. Therefore designed test stand will be equipped with brushless linear magnetic motors supporting adequate parameters.

It was also interesting to know whether effective machining out of focus could be realized in order to improve the quality and precision of the cutting edge [7]. Another simulation was prepared for laser parameters same as in previous simulation, but focused beam waist was wider  $d_f=30\mu m$ . Results of the modelling were presented on the figures below – Figs. 3 and 4.

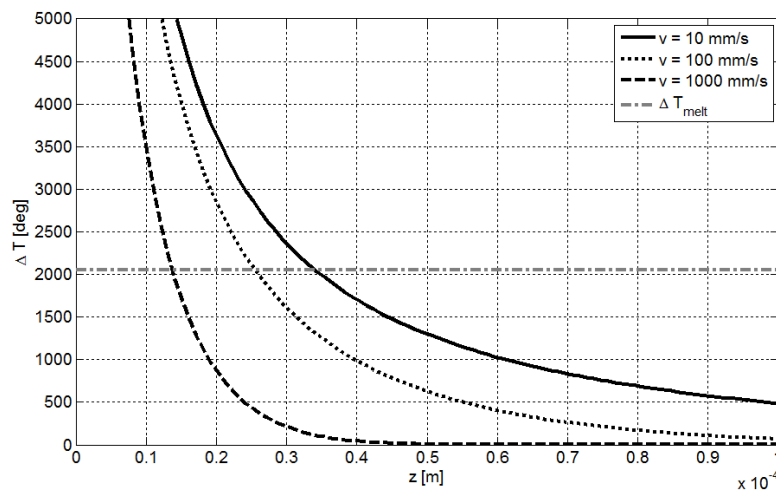

Fig. 3. Temperature rise inside the material depending on cutting speed. Dashed horizontal line represents melting point.

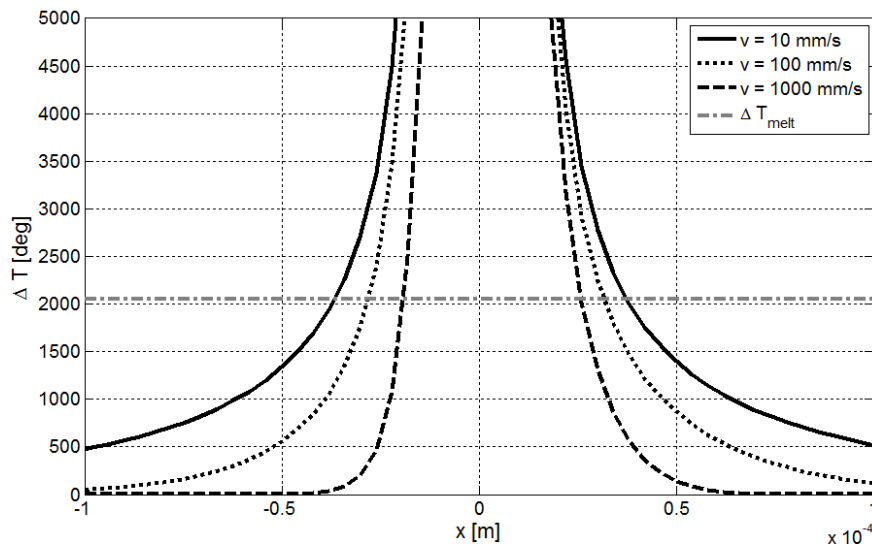

Fig. 4. Temperature rise on the surface of the material depending on cutting speed. Dashed horizontal line represents melting point.

It can be noticed that even out of focus processing may result in material machining. Therefore during empirical test this information will be very important for definition of tool affected zone (TAZ) [7].

To prepare the test stand for laser precise machining several assumption were considered. The most important is possibility of beam size manipulation for effective lens functionality, application of attenuator in order to control laser power without changing the beam geometry, active polarizer to keep electrical vector perpendicular to cutting speed vector during curvilinear cutting. The most important factors for LBM were presented in Fig. 5.

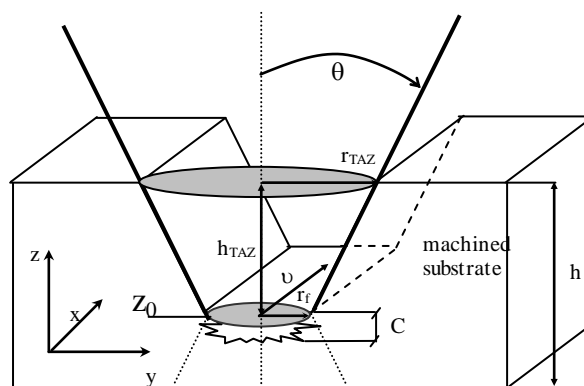

Fig. 5. Scheme of laser machining [7]

Work stations – Fig. 6, will be equipped with XYZ table working in 2.5D regime, the laser source and set of optical components used to control the laser beam parameters. The laser beam can be enlarged to the desired diameter with the expander.

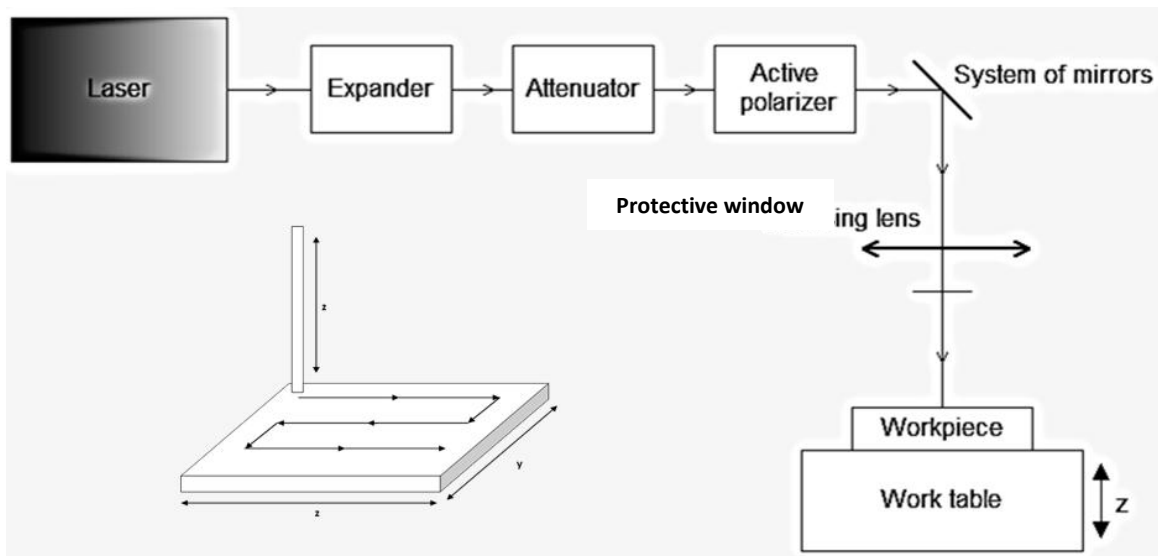

Fig. 6. Conception of research test stand and the scheme of laser beam machining

Attenuator is a passive optical component designed to reduce the transmitted power without influence on beam geometry and energy distribution. The power of beam after passing through this optical element will be reduced to the desired level of the operating range. Another element is the active polarizer used to configure the type of polarization. As has already been said the type of polarization strongly determines precision and quality of the machining. To change the polarization the half-wave plate is used.

By using the system of two mirrors it is possible to control two degrees of freedom. Which greatly facilitates setting the laser beam on perpendicularly on the working surface. The last elements are the focusing lens and window protecting laser system against reflected laser beam. It should be particularly important to set adequate distance between the lens and the workpiece. Otherwise improper distance may lead to major defects of machined surface. The correct position is when the focal point is located on a machined surface.

## 5. REMARKS

As it results from prepared simulation one can expect that use of configuration of long focal length focusing lens would enable cutting with excellent precision and acceptable efficiency of material removing rate. For cutting with use of focused laser beam up to ca.  $9 \mu\text{m}$  and cutting speed ca.  $10 \text{ mm/s}$  one can expect the cutting slit about  $90 \mu\text{m}$  wide and about  $35 \mu\text{m}$  deep. In case of cutting thick materials obtained data would be helpful to determine  $x$ ,  $y$  and  $z$  step for machining in 2.5D regime according to presented on Fig. 5 and Fig. 6 schemes. Further research will be focused on designing, assembling and setting the laser system verification of modelling results and extension of mathematical model in order to improve efficiency and accuracy of the process as well as limit the time and cost of material processing.



## ACKNOWLEDGEMENTS

*This research was supported by a grant no NR03-0031-10/2010 from National Centre for Research and Development, Poland.*

## REFERENCES

- [1] DOBROVINSKAYA E., LYTVINOV L., PISHCHIK V., 2002, *Sapphire & other corundum crystals*, Folio Institute For Single Crystals, Ukraine Kharkiv.
- [2] OGURA G., ANGELL J., WALL D., 1998, *Applications test potential of laser micromachining*, Laser Focus World, 34, 117–123.
- [3] DUBEY A. K., YADAVA V., 2008 *Experimental study of Nd:YAG laser beam machining—An overview*, Journal of Materials Processing Technology, 195, 15–26.
- [4] MEIJER J., DU K., GILLNER A., HOFFMANN D., KOVALENKO V.S., MASUZAWA T., OSTENDORF A., POPRAWA R., SCHULZ W., 2002, *Laser Machining by short and ultrashort pulses, state of the art and new opportunities in the age of the photons*, CIRP Annals - Manufacturing Technology, 51/2, 531–550.
- [5] WYSZYNSKI D., SKOCZYPIEC S., GRABOWSKI M., RUSZAJ A., LIPIEC P., 2012, *Electrochemical microprocessing assisted by diode pumped solid state Nd:YAG pulse laser*, Journal of Machine Engineering, 12/1.
- [6] POPRAWA R., 2011, *Tailored Light 2 - Laser Application Technology*, Springer-Verlag Berlin Heidelberg.
- [7] WYSZYNSKI D., 2009, *Taking into account the influence zone of laser bundle in processing of diament*, Inżynieria Maszyn, R. 12/4, 94-102, (in Polish).