

Aleksander KRAS<sup>1</sup>  
Frederic BOURGAIN<sup>1</sup>  
Frank CLAEYSSSEN<sup>1</sup>

## **AMPLIFIED PIEZO ACTUATOR APA® WITH VISCOELASTIC MATERIAL FOR MACHINE TOOL SEMI-ACTIVE DAMPING SYSTEM**

Modern machine tools must achieve a high precision for a better surface texture and higher flexibility for wide range of machining requirements. To fulfill these requirements, a semi-active damping system for a new generation of machine tools is proposed. The new concept is partially based on the Amplified Piezo Actuators APA® from CEDRAT Technologies. With these actuators, the dynamic behavior (stiffness and damping) of structural body components of machine tools can be controlled and adjusted to the optimum parameters. To reduce the transfer of vibrations through the active elements, a viscoelastic material was used. This article presents test results performed on the APA® with viscoelastic material. A significant reduction of the vibrational amplitude at resonance frequency was observed with additional material. The optimized quantity of viscoelastic material reduces the full stroke of the actuator only by 10 percent. At the same time, the viscoelastic material has reduced the amplitude at resonance frequency by more than double. The designed actuator obtains a blocking force of 8.5kN. Results obtained from the tests performed on the machine tool showed significant surface texture improvement with use of the amplified piezoelectric actuator.

### **1. INTRODUCTION**

During the work of the machine tool, different types of loads act, and they can be classified by the sources. In fact, three main types can be defined: the first type of load is caused by the machining process, and influenced by the feed rate, spindle speed, properties of cooling liquid, etc. The second type of load is caused by the workpiece to be machined and tools used in the process. This includes the radius of the tool, the mass and geometry of the workpiece, the clamping method used, etc. The third type of load is caused by working parts of machine tool: motors, gears, shafts, bearings, rotating elements, etc. [1]. All loads cause vibration of the machine tool and have influence on the surface texture and quality of finished workpiece.

Vibrations especially at resonance frequencies cause limits of using some of the machining parameters. For the high performance cutting (HPC) process, which is a leading technique nowadays, the machines face the problem of parameters limitation due to

---

<sup>1</sup> Cedrat Technologies, 59 Chemin du Vieux Chêne, Inovallée, 38246 Meylan, France, [www.cedrat-technologies.com](http://www.cedrat-technologies.com)  
E-mail: [aleksander.kras@cedrat-tec.com](mailto:aleksander.kras@cedrat-tec.com)

excessive vibration. Limitations are defined by the stability lobe diagram (Fig. 1). The use of smart tools like viscoelastic materials and piezoelectric actuators is one of the methods to increase the range of machining conditions.

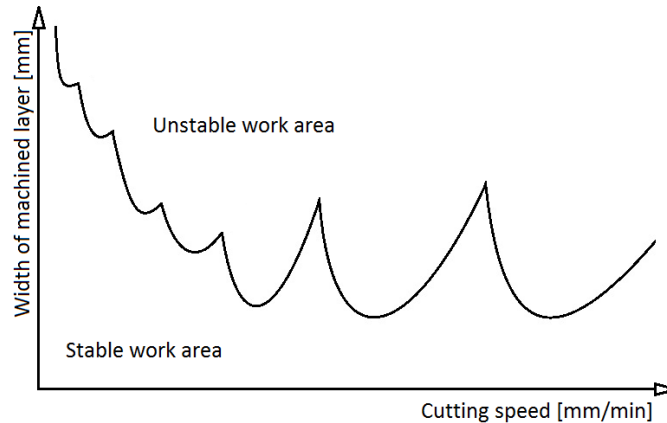

Fig. 1. Stability lobe diagram of typical machine tool

The machine tool manufacturers try to improve the stiffness of the joints in machine tool–fixture–workpiece–tool system. This connection is the most vulnerable for the whole machining process. Improvement of these joints will have a direct impact on the improvement and quality of the workpiece.

This improvement is one of the main tasks of the European Union project called PoPJIM (Plug and Produce Joint Interface Modules) [2]. The main goal of this project is to create a machine tool with zero defects on complex elements [3]. A self-optimizing mechatronic joint is one of the main innovations in this project. This mechatronic joint would control the dynamic behavior of machine tool during machining process. To develop this joint, a combination of smart materials with piezoelectric actuators was proposed.

Controlling the actuators, the operator could change the stiffness within the joints. By controlling the dynamic characteristic of the machine, it would be possible to obtain the required machining parameters.

## 2. SMART ACTUATORS IN MACHINE TOOLS

Based on many examples, the smart actuators can be successfully implemented in the damping systems of the machine tool. This trend started many years ago and since then it has expanded. There are many ideas and systems in the machine tool, in which smart actuators can be used. Some of the applications, that use smart actuators to improve machining process are described in this paragraph.

CEDRAT Technologies had a lot of success in development of the mechatronic systems for the machine tools. In 2004, collaborating with Hanover University, a tool adaptor for active vibration control was created (Fig. 2).

The active element is a piezoelectric actuator, which is a standard product of CEDRAT Technologies. The tool works in the close loop control system with the force sensor and Parallel Pre-stressed Actuator (PPA®). The tool adaptor has compact size of 62mm in diameter, and 125mm of length, and it has been equipped with standard VDI-3425 interface. The used actuator in the tool adaptor can generate 3.5kN of force with maximum displacement of 40µm. As shown by the test results, these parameters are sufficient to improve the surface quality of the workpiece.

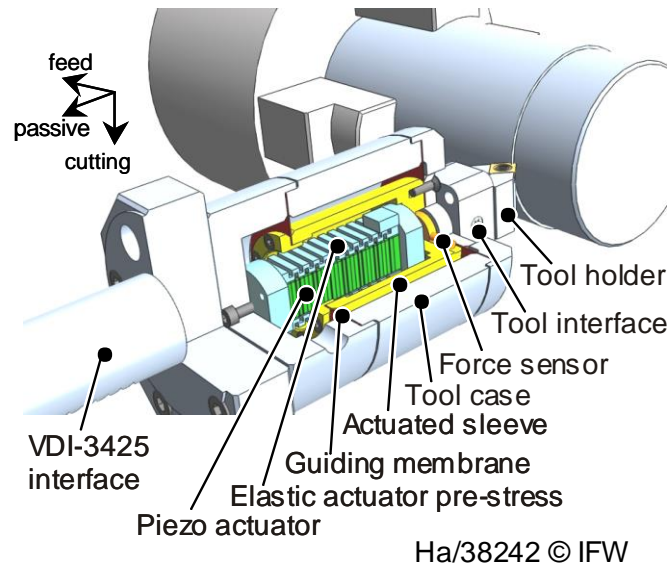

Fig. 2. Active tool adaptor based on PPA®

During the tests, the tool adaptor has shown to have a good damping capability resulting in a 16dB decrease in amplitude for a bending mode at 500Hz [5],[6].

The other mechanism with smart actuators, that was proposed for chatter suppression was the tuned-mass damper. This device was developed for SORALUCE milling machine in cooperation with IK4-IDEKO. The self-tuning damper was designed with the required specifications, and uses eddy current forces to generate damping. The total dimensions of the damper are 200x150x150mm, with total mass of 7kg. The tuned-mass damper was design to detect chatter of the machine tool, and automatically tune to the frequencies between 66 and 105Hz, with total damping of 700Ns/m [7]. Those parameters were set based on numerous tests performed on the milling machine.

The tuned-mass dumper was designed fulfilling all the required parameters. The mechanism was tested, on the machine tool, during the machining process. For the tests a metal block was machined with increasing depth of cut. After performed tests it was concluded that the tuned-mass damper showed improvement in the machining process. Without the damper the chatter appeared for 3mm depth of cut while with the dumper no chatter marks were observed even for a 5mm depth of cut. This mechanism presents a good damping capability for chatter suppression.

As often for dampers, the smart actuators are used for vibration generation to improve the machining process. The idea of using the smart actuators as a vibration generator was used in a rotation free linear actuator developed by CEDRAT Technologies. The concept was based on the piezoelectric actuators which were used to create the axial vibrations of the drilling tool. The mechanism was designed to improve the drilling process for difficult machining materials, like titanium or composites (Fig. 3).

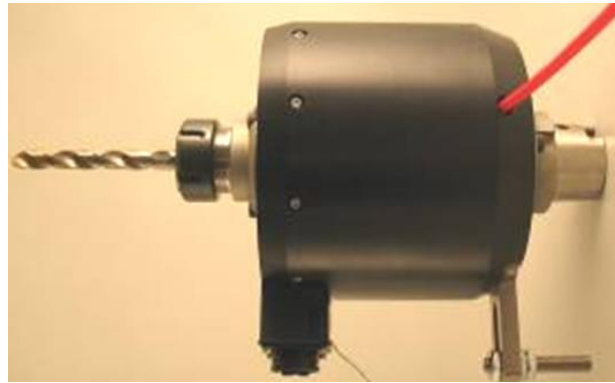

Fig. 3. Rotation free linear actuator

The rotation free linear actuator generates axial vibrations adjusted to the angular velocity with a stroke of hundreds of microns. Those small vibrations improve the chip generation during the machining process. The piezoelectric actuators generate small retractions of the drill, which causes breaking of the continuous chips.

Performed tests with rotation free linear actuator on the machine tool showed significant improvement in drilling process. Two types of the materials were chosen for the tests. The first material was titanium due to the high hardness. The second material was aluminum due to the easiness of continuum chip generation. During the drilling process, the generated vibrations changed the chip type (Fig. 4). Without the vibrations the chip was continuous, while with the vibration assistant the chip was segmental. These tests showed major improvement in the machining process for both materials.



Fig. 4. Influence of the vibration generator

The additional advantage of the mechanism is the time required for the installation. The rotation free linear actuator was designed with the standard HSK interface, and it can be installed on the machine tool in less than 10min [8].

The piezoelectric actuators can be also used for creation of the force oscillators. Based on the low voltage piezoelectric ceramics a high force oscillator was designed at CEDRAT Technologies. The small vibrations generated by the oscillator can be used to reduce the stick-slip effect in the machines. It was observed that additional dynamic forces improve the sheet metal forming process. The oscillator was designed to withstand external loads, and to produce high dynamic forces. The designed force oscillator can generate 26kN of force with a maximum displacement of 60 $\mu$ m. Those parameters can be used in the frequency range from 0 up to 200Hz.

All presented mechanisms based on the smart actuators show significant improvement in the machining process. The piezoelectric actuators and smart materials present numerous advantages that can be used in the machine tools systems.

### 3. DEVELOPMENT OF THE ACTUATOR

All advantages of the smart tools induce in use of piezoelectric elements in the new chatter suppression mechanism. In the European Union project called PoPJIM (Plug and Produce Joint Interface Modules) it was decided to use the piezoelectric actuators. This project was concentrated on two innovations in future machine tools. The first concept was focused on the mechatronic joint, which will control the dynamic behavior of the machine. The second concept was focused on the distributed wireless communication network which will be used to control those mechatronic joints.

CEDRAT Technologies was involved in the development process of the mechatronic joint. The idea was partially based on amplified piezoelectric actuators (APA®). There are three mayor advantages in terms of use of APAs®. First of all, the amplified actuator can provide a large force. The second advantage is that they are electrically driven and positioning resolution is within a couple of nm. The third advantage is the lack of any fluids. This makes them environmentally friendly. All three mayor advantages made piezoelectric actuators suitable for this application.

### 4. DESIGN

The procedure for designing a new actuator was begun with a definition of requirements. The two most important requirements were the maximum generated blocked force, and the stroke of the actuator. Based on both requirements a new actuator was designed at CEDRAT Technologies. To increase the maximum force the actuator was designed with two parallel positioned stacks of ceramics (Fig. 5). These ceramics were custom made for this project in collaboration with CeramTec GmbH [4]. The piezoelectric

was locked in the metal cover which protects the ceramics from any fluid or dust. This protection increases the lifetime of the sealed ceramics, especially because multilayers ceramics are known to be weak when used in DC application in a humid environment [4].



Fig. 5. Custom made piezoelectric ceramics

The geometry of the custom made actuator was based on a CEDRAT standard product, the APA®95ML. This new actuator obtained the code name APA®95-PTW-MD (Fig. 6). The PTW abbreviation stands for parallel twin and MD code for mechanically damped.



Fig. 6. APA®95-PTW-MD actuator

The designed APA® is improved compared to the standard version with the additional support. This support has two major tasks. It connects the bottom and top of the APA® with layers of viscoelastic material (VEM). It is also used as a holding element for the displacement sensor. The main objective of the viscoelastic material is to prevent the direct vibration transfer between the two sides (top and bottom) of the actuator. Two types of viscoelastic materials were used (Fig. 7). The first used VEM was the 130µm thick polymer. The second one, 300µm thick, was the EDS material. This material was a combination of a metal matrix and carbon nanoparticles.

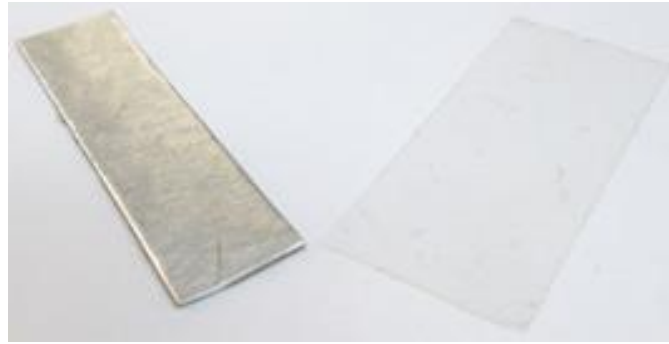

Fig. 7. Two types of VEM used in damped actuator

Before manufacturing the new APA®, a series of tests were performed on a standard actuator APA®95ML. The tests were done to choose the viscoelastic material type, and to evaluate the optimum number of layers.

## 5. STROKE TEST

The first test that was performed on the APA® with viscoelastic material was the measurement of maximum displacement. This test was performed to verify the influence of the additional material on the stroke of APA®. After this test the maximum stroke of the actuator with additional material was obtained. To measure the stroke of the actuator an electrical sinus signal was applied to the actuator. The driving voltage was the signal from -20V to 150V ( $\Delta 170V$ ) with 1Hz of frequency. To measure the displacement a capacitive sensor was used. This test was performed for both types of viscoelastic materials. The value of stroke was measured for a different number of layers. For the thin ( $130\mu m$ ) material the stroke test was repeated with up to 7 layers (Fig. 8 to the left). For the thick ( $300\mu m$ ) material the stroke test was repeated with up to 5 layers (Fig. 8 to the right). Based on the test results, the optimum number of layers was defined.

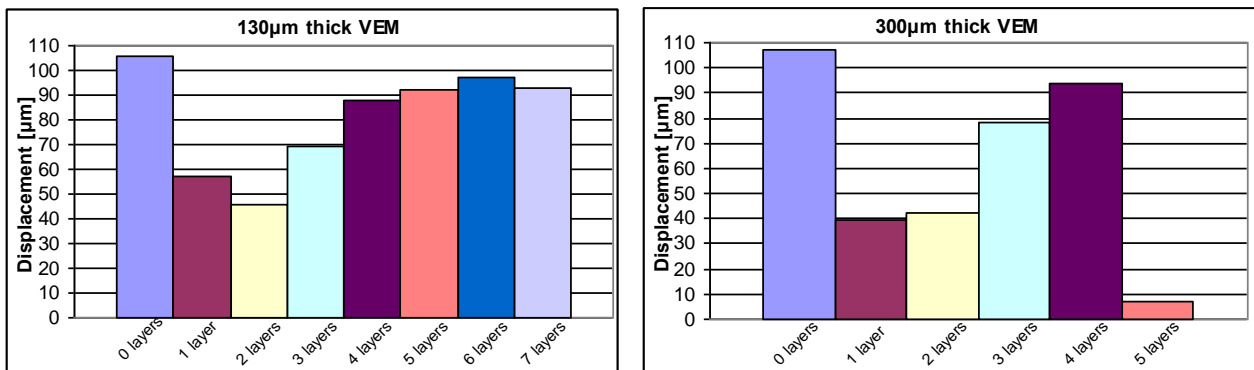

Fig. 8. Stroke measurement for  $130\mu m$  (to the left) and  $300\mu m$  (to the right) thick VEM

For 6 layers of 130 $\mu\text{m}$  VEM the maximum stroke of the actuator was 96.8 $\mu\text{m}$ . For 4 layers of the 300 $\mu\text{m}$  VEM the maximum stroke was 93.6 $\mu\text{m}$ .

As expected the stroke of actuator increases with number of layers. However the stroke has maximum value, and later it starts to decrease. For the thin viscoelastic material the optimum number is 6 layers, while for the thick material this number is 4 layers.

## 6. ADMITTANCE TEST

A similar test to the stroke measurement was performed to obtain admittance curve of the actuator. The admittance test is performed as a sweep for a set frequency range. This range depends on the size and type of the actuator. For the APA<sup>®</sup> with additional material the frequency range was set from 1kHz to 15kHz. Because the tests were performed for the wide frequency range the excitation voltage was set to 0.5V.

The APA<sup>®</sup> was tested for the same number of layers as in the stroke test. For the thin material this test was repeated with up to 7 layers (Fig. 9 to the left).

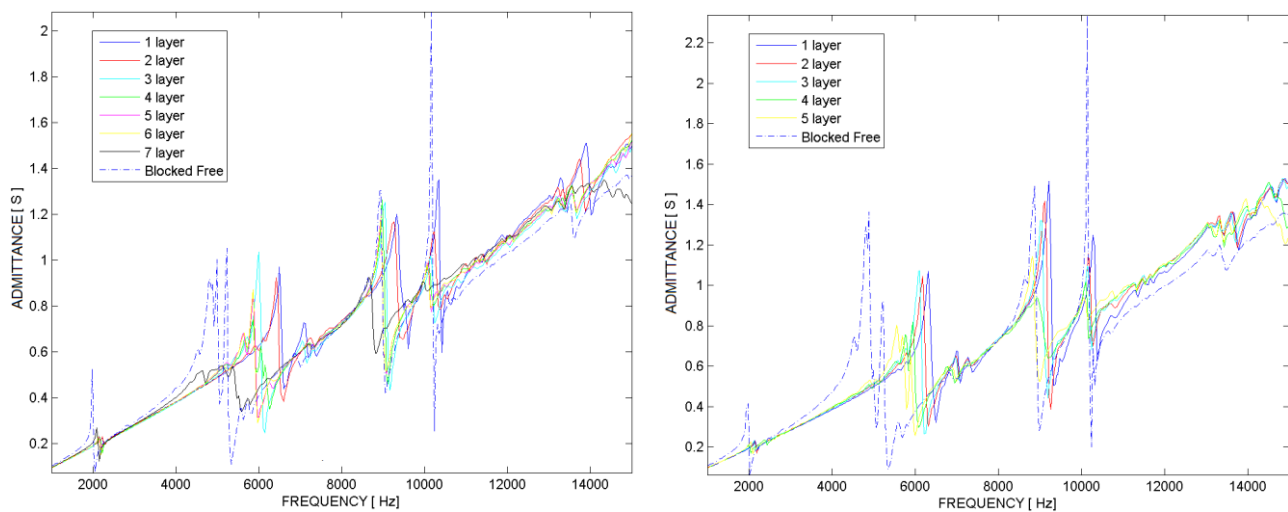

Fig. 9. Admittance curves for 130 $\mu\text{m}$  (to the left) and 300 $\mu\text{m}$  (to the right) thick VEM

For the thick material admittance test was repeated with up to 5 layers (Fig. 9 to the right). It is shown in the graphs the additional layers of VEM in the actuator increases the resonance frequency. It was also observed that the additional material decrease the peak value for the first mode. Even with just one layer of the additional viscoelastic material a significant reduction of the quality factor can be observed.

High resonance frequency and a low quality factor are desired parameters for static applications. A reduced quality factor gives significant advantages in terms of closed loop control. The actuator is more stable and controllable in the change of the frequency.



## 7. EXCITATION TEST

A final test performed on the APA® with the viscoelastic material was the excitation test. This test was performed to simulate the real condition in which the APA® with additional material will be working. To excite the designed actuator a small parallel piezoelectric actuator PPA® was used. The advantage of the PPA® is that the first resonance frequency of this actuator is far above the measurement range. To the other side of the APA® a mass was added which was simulating the damped element of the system. During the test a sweep sinus signal was applied on the PPA®. Three measurements were performed in which displacement of PPA® and of the mass were monitored. In the first measurement the APA® was not equipped with the VEM. In the second measurement the APA® was equipped with 6 layers of 130 $\mu$ m thick VEM material and there was no voltage applied. In the final measurement the equipped APA® was supplied with a 150V DC voltage. To observe the damping capabilities of the actuator a mathematical operation was performed on the obtained signals. The displacement of the mass was subtracted from the displacement of the PPA®. This operation was performed for all three measurements (Fig. 10).

It can be observed that for small values of the frequency the additional material does not reduce the transfer of vibration. However the improvement can be observed for higher frequencies. The peak value that appears at 3500Hz is shifted to a higher value of frequency. This shift can be observed at both 0V and 150V applied on the APA®. This indicates that the stiffness of the system changes, and causes a shift of the resonance frequency.

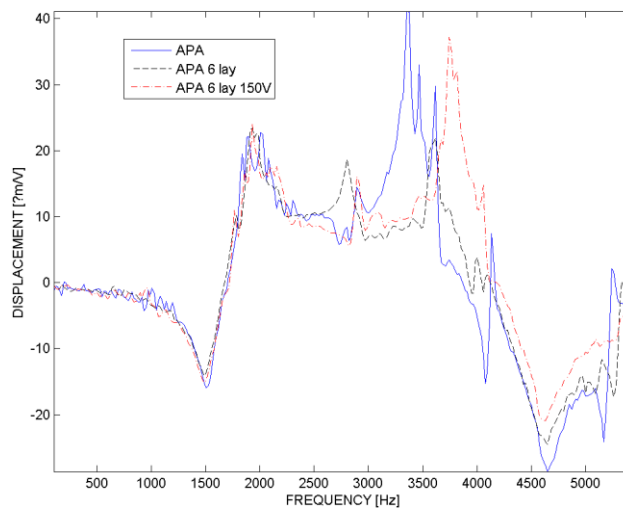

Fig. 10. Actuator vibration transfer

For a small prestress of the VEM, the additional material damps the transfer of the vibrations. This can be observed on the graph comparing the dashed curve with the solid one. Increase of voltage on the APA® causes increase of VEM prestress. This causes an increase of the stiffness in the system, and change of the resonance frequency. This can be observed on the graph comparing dash-dotted curve with the solid one.

## 8. BLOCKED FORCE TEST

One of the project requirements was to measure the force that can be obtained with the designed actuator. The maximum force generated by the actuator had to be tested on the dedicated test bench. This required designing a blocked force test bench (Fig. 11).



Fig. 11. Blocked force test bench

The idea of the test is to locate the actuator in the blocked-blocked condition with a force sensor on one end. Applying the maximum voltage at certain frequency the APA<sup>®</sup> generates maximum force which is measured with the sensor.

Based on the simulation, the maximum blocked force of the actuator was evaluated to be 9kN. With the tests performed on the dedicated test bench, the maximum measured blocked force was 8.5kN.

Additionally for the closed loop control system it was required to verify the blocked force with the change of the applied voltage. A set of tests showed that the force generated by the actuator in the change of the voltage is linear, and equals to 50N/V. This gives a huge advantage in the control system of the actuators. With the change of the applied voltage the stroke and the force can be controlled.

## 9. SENSOR INTEGRATION

For the closed loop control an eddy current sensor was integrated in the supports (Fig. 12). Two sensors were used per actuator.

The main idea was to place the sensors in the support, which is stable, while the actuator is moving. The sensors were placed facing the actuator. While the APA<sup>®</sup> is moving it contracts the VEM causing a reduction of displacement between the metal shell and the

support. This displacement is measured by the eddy current sensors. The comparison between the assembled actuator and actuator at full stroke is presented (Fig. 12 to the right).

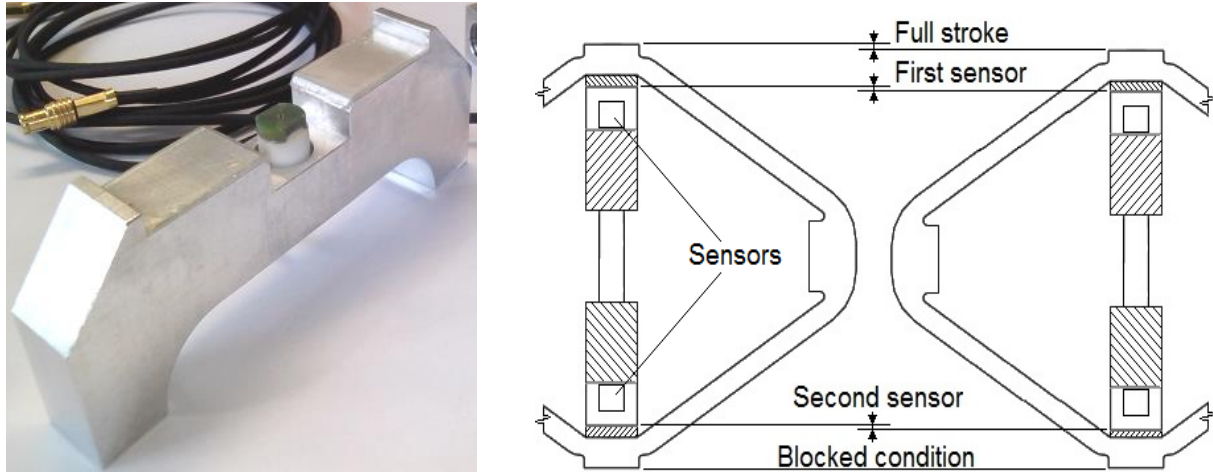

Fig. 12. View of the sensor in the one part of support and the principle of the displacement measurement by the eddy current sensors

Both sensors were placed in the center of the support. Placing the sensors in the middle provides an ideal measurement position for two parallel ceramics. To use the eddy current sensors in closed loop control, they are calibrated based on the maximum stroke of APA®.

## 10. MACHINE TOOL INTEGRATION

The PoPJIM project is concentrated on the improvement of the machining process in the lathe. With the use of the piezoelectric actuators and the viscoelastic material, the machine tool chatter damping capabilities would be improved.

The dedicated actuators were designed to be placed in the tailstock of the lathe (Fig. 13). Two actuators are located on the sides of the tailstock. Through special interfaces the actuators connect two parts of the tailstock. Between those parts a thin layer of viscoelastic material is placed. To change the stiffness in the system and to improve the damping capabilities of the lathe, the viscoelastic material is being compressed. To change the prestress level of the viscoelastic material the piezoelectric actuators are used.

The whole system works in the closed loop control system. The vibration of the machine tool is sensed by the accelerometer. At the same time the displacements of the actuators are measured with the eddy current sensors. Both signals are being sent to the control computer. The dedicated computer software processes the data coming from the accelerometer and the eddy current sensors. Based on both signals a new position of the actuator is determined.



Fig. 13. Location of the APA® on the tailstock

As the displacement of the actuator changes the viscoelastic material is compressed or relieved. This changes the dynamic behavior of the machine tool which is adjusted to the vibration amplitude.

## 11. EXPERIMENTAL VALIDATION OF THE DAMPING SYSTEM

To verify the damping capabilities of the semi-active system, numerous of tests were performed on the lathe. The tests were performed on a CNC TAE35N lathe. Sets of experiments were performed to define the machining parameters in which the chatter appears. It was observed that the chatter appears with a depth of cut of 1.5mm and a 28mm diameter bar (Fig. 14 to the left).



Fig. 14. Appearance of the chatter on the machined bar and machining with semi-active damping system

After obtaining the machining parameters in which the chatters appears, the semi-active damping system was installed in the lathe (Fig. 13). The tests on the metal bars were repeated with the defined parameters of depth of cut and the diameter. With the working semi-active damping system the machined surface was improved (Fig. 14 to the right).

With the performed tests it was validated that the system works and suppress the chatter of the lathe machine tool.

## 12. CONCLUSIONS

A new actuator with parallel positioned ceramics was designed at CEDRAT Technologies. This actuator can generate up to 8.5kN of blocked force within a low space requirement. The support with the additional viscoelastic material can significantly improve the mechanical parameters of actuator. The actuator with additional material changes the stiffness and damping characteristics of the machine tool.

Based on the results from all performed tests, optimal number of layers and the type of viscoelastic material was chosen. The 130 $\mu$ m polymer with 6 layers was mounted on the supports. The additional material is elastic enough to be compressed, it causes an acceptable reduction (<10%) of the actuator maximum stroke.

The additional support system was also used to integrate the eddy current sensors. These displacement sensors will be used in local control loop system. The change of actuator displacement will change the stress on the viscoelastic material and will also change the dynamic behavior of the joint.

Preliminary tests with designed joint showed a significant reduction of chatter. Further tests are expected to be performed on the machine tool with a semi-active damping system. The support system with the viscoelastic material and with eddy current sensor integrated in the piezoelectric actuator can also bring benefits in many other applications.

## ACKNOWLEDGEMENT

*This development has been done in the framework of the European project FP7: PoPJIM: Plug and Produce Joint Interface Modules, grant agreement n°260048. [www.popjim.com](http://www.popjim.com)*

## REFERENCES

- [1] SKOCZYŃSKI W., 2001, *Evaluation of property of machine tools on basis of accuracy of processing tentative objects*, Oficyna Wydaw. PW, Wrocław, ISSN 0867-5325, (in Polish).
- [2] [www.popjim.com](http://www.popjim.com)
- [3] Concept and project objective, FP7: PoPJIM, 2010, *Description of work plug and produce joint interface modulus*, June 2010.
- [4] [www.ceramtec.com](http://www.ceramtec.com)

- [5] HARMS A., DENKENA B., LHERMET N., 2004, *Tool adaptor for active vibration control in turning operations*, ACTUATOR, 14-16 June 2004, 85, 694-697.
- [6] Compact Dynamic Precise, 2012, CEDRAT TECHNOLOGIES product catalogue, v4.1, Meylan, France, November.
- [7] AGUIRRE G., GOROSTIAGA M., PORCHEZ T., MUÑO A J., 2012, *Self-tuning semi-active tuned-mass damper for machine tool chatter suppression*, December. <http://www.cedrat-technologies.com/fr/publications/categories/device-systems/active-control-of-vibration/proof-mass-damper.html>
- [8] PAGÈS F., CLAEYSSSEN M., MIHOUD M., BAGOT A., 2012, *Rotation free linear actuator*, ACTUATOR, 18-20 June 2012, 1/6, 72-75.